

40-0451 Measuring steering knuckle

Preceding work:
Steering knuckle removed

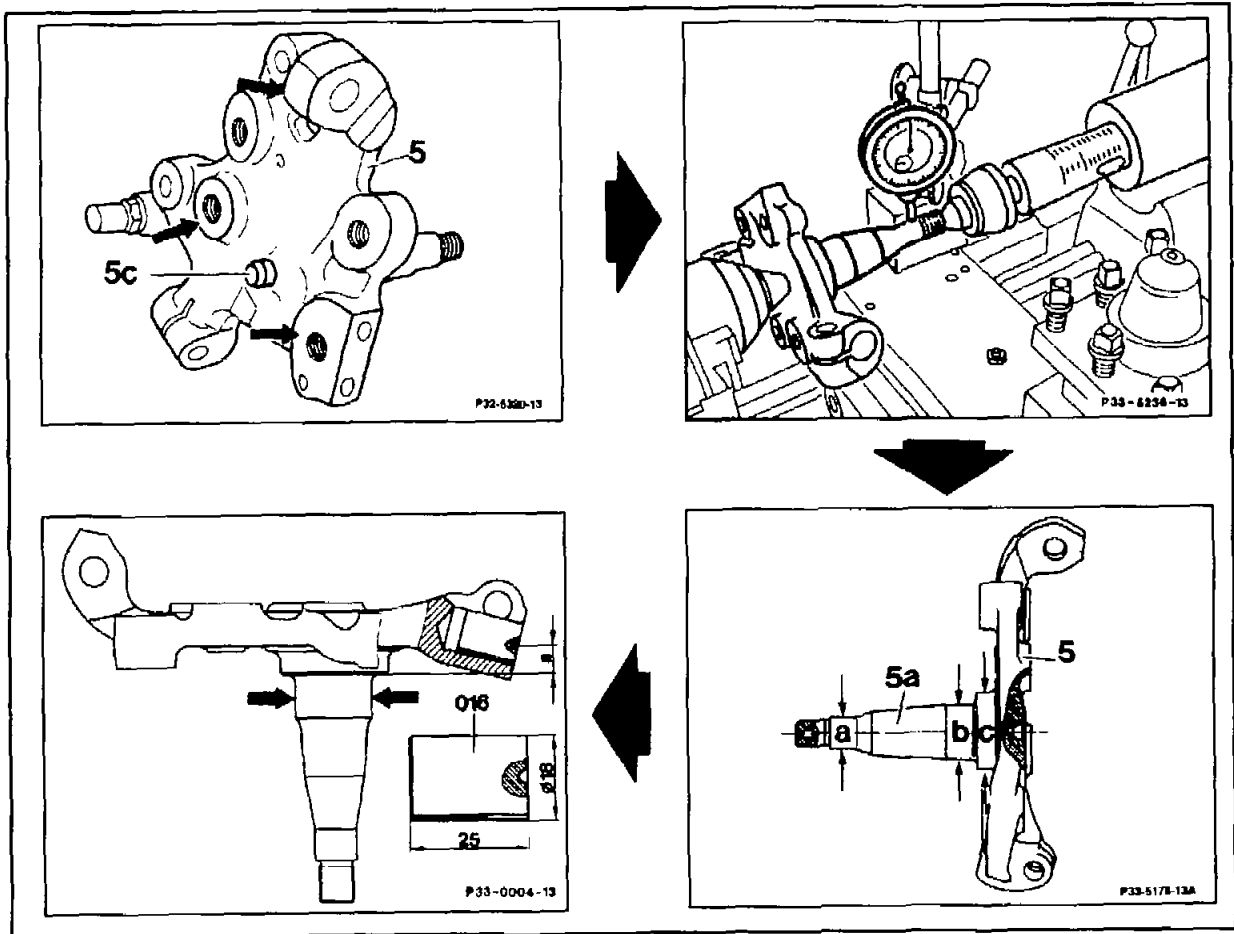

P33-5111-57

Centering pin (5c)
Kingpin (5a)

Drive out of steering knuckle (5) with a chisel.
Check for external damage and concentricity, by holding steering knuckle at both centering holes between the centers of a lathe. Check for permissible runout (0.05 mm) using dial gauge by slowly turning by hand.

- Bearing seat (a, b) Check for wear.
- Bearing surface (c) Check for wear and scoring.

Special tools

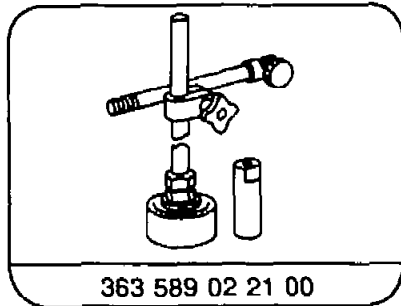

Commercially available tools or testers, MB testers (refer to Workshop Equipment Manual)

Designation	e.g. Company, order no.
Dial gauge A1 DIN 878	Mahr Esslingen Order no. 311 000

Note

In the case of accident repairs, the steering knuckle can also be checked for distortion in the camber direction via the lower bearing point, after checking the kingpin with the aid of a measuring pin. The steering knuckle is held in a three-jaw chuck on the inner bearing seat of the pin (arrows).

To evaluate, the difference (a) between the contact surface for the inner tapered roller bearing and the mounting hole for the ball pin of the supporting joint is measured with a height measuring gauge. The measuring pin must be flush with the end face of the mounting hole.

The reference dimension "a" should be 12.5 ± 0.5 mm.

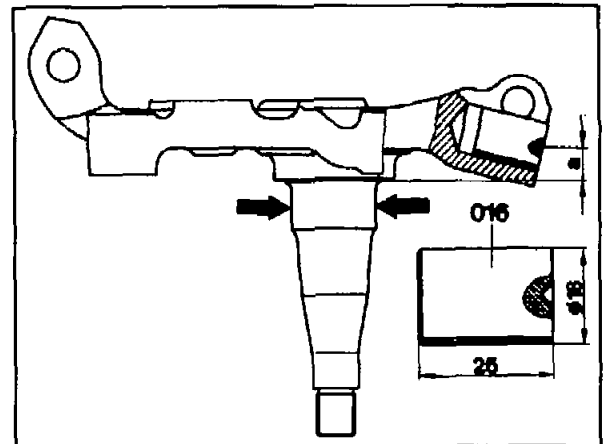

P33-0004-13

016 Measuring pin with centering hole (shop-made)