

32-0530 Testing pressure oil pump and level controller on rear axle (models 124 and 201 with level control on rear axle)

Operation no. of operation texts and work units or standard texts
and flat rates:
32-0753

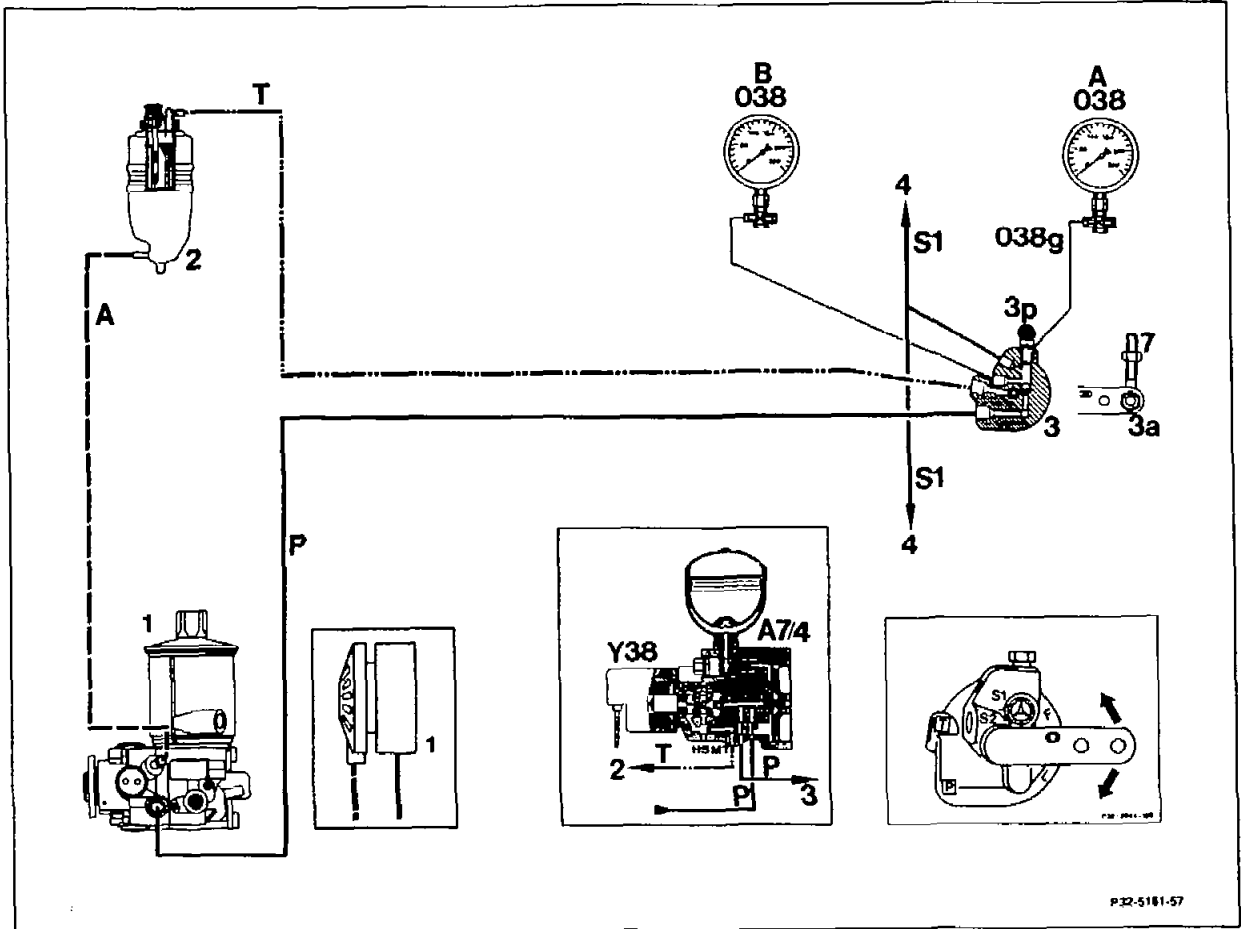

- | | |
|--------------------------|--|
| Oil reservoir (2) | Check oil level and top up if necessary (step 1). |
| Connecting rod (7) | Disconnect, connect at level controller (3);
replace self-locking hexagon nut, 10 Nm (steps
2 and 18). |
| Oil drain hose | Connect, disconnect at oil drain plug (3p) on
level controller (3) (step 3). |

Oil drain plug (3p)	Open slowly, release pressure and collect the oil in a clean container. Then unscrew oil drain plug (steps 4 and 5).
Pressure tester (038)	Connect to level controller with test hose (038g) (step 6).
Engine	Start, switch off.
Lever (3a) on level controller	Move to "filling" position (step 8).
Pressure tester (038)	The needle of the pressure tester 126 589 14 21 00 must indicate a pressure of at least 133 bar (step 8).
Lever (3a) on level controller	Move to "emptying" position (step 10).
Pressure tester (038)	Read off basic pressure. Minimum pressure 30 + 6 bar (steps 11 and 12).
Oil drain hose	Disconnect, connect at bleed screw on pressure tester (step 13).
Bleed screw on pressure tester (038)	Open slowly, release pressure and collect the oil in a clean container (step 14).
Pressure tester (038)	Disconnect at level controller (3) (step 15).
Oil drain plug (3p)	Screw into level controller (3), 14 Nm (step 15).
Pressure oil system	Fill (32-0630).
Oil level in oil reservoir (2)	Check and top up if necessary with hydraulic oil (see Service Products table) using funnel 126 589 12 63 00 (step 19).

Service products

Hydraulic oil	See MB Specifications for Service Products, sheet 343 (1.0-liter can, part no. 000 989 91 03/10)
---------------	---

Test data

Pressure-relief valve (level controller)

133–153 bar

Basic pressure

Minimum pressure 30 + 6 bar

Special tools

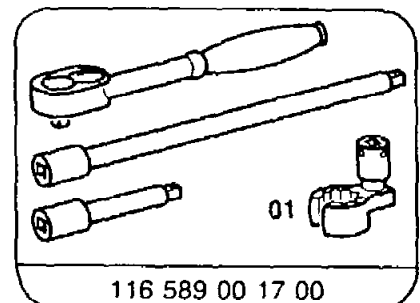
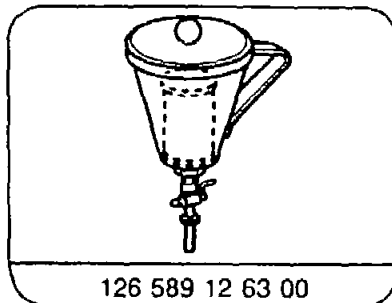
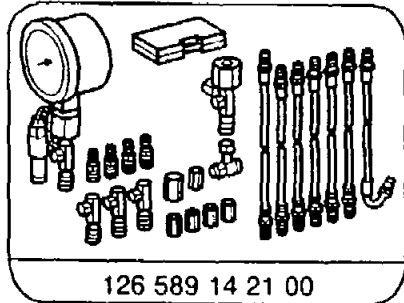

Notes

The following parts of the tester are required for the test work:

Pressure tester (038) with connector and union nut with sealing ring, test hose (038g) and bleed screws.

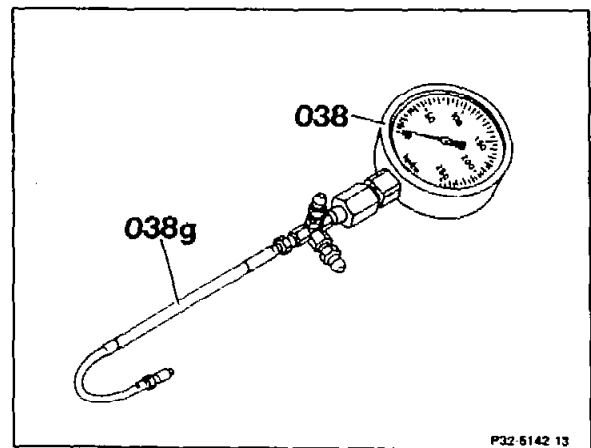

In vehicles up to approx. 12/87 a contaminated oil filter may falsify the results of the oil level check.

For this reason, the oil filter must be removed and inspected for contamination when checking the oil level.

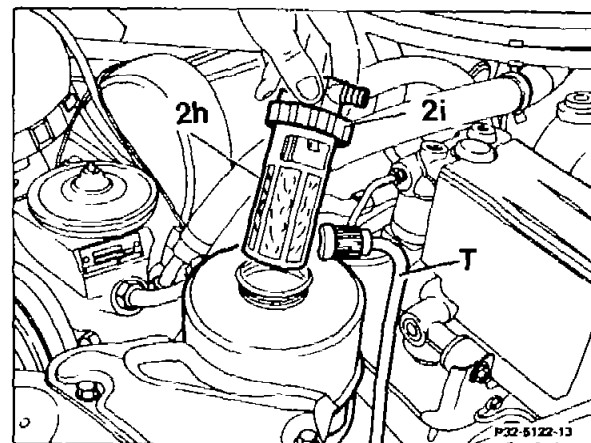

- 2h Oil filter
- 2i Union nut
- T Return line

1 Check oil level in oil reservoir (2) and top up if necessary.

Note

In the ready-to-drive condition, the oil level should be between the "min" and "max" marks when the engine is switched off.

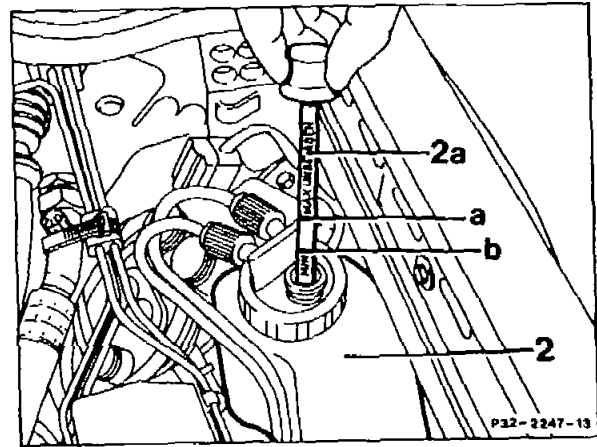

Arrangement on model 124

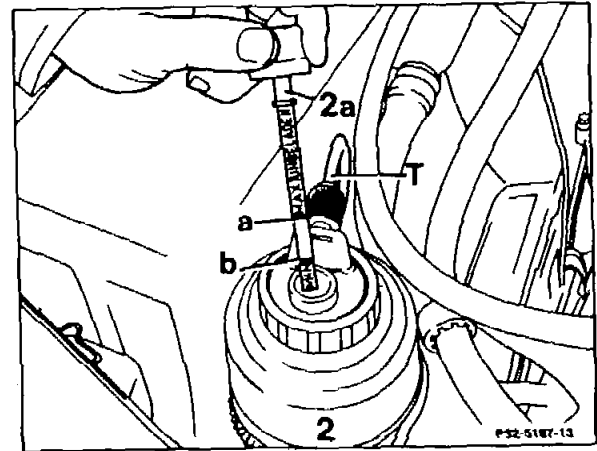

Arrangement on model 201

- 2 Oil reservoir
- 2a Cap with oil dipstick
- a Maximum mark
- b Minimum mark

2 Unscrew self-locking hexagon nut (7a) and detach connecting rod (7).

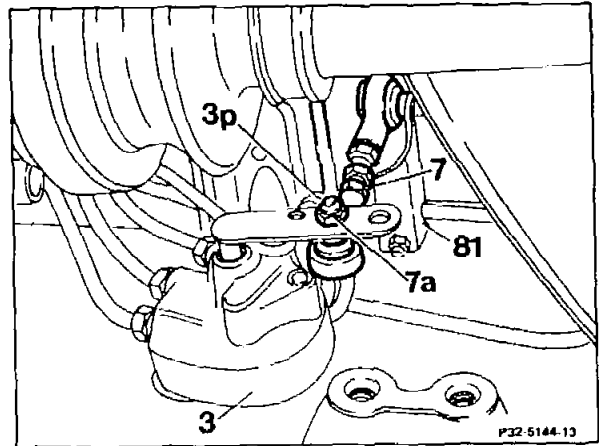

3 Connect oil drain hose (061) to oil drain plug (3p) on level controller.

4 Slowly open oil drain plug (3p) and release pressure. Collect the oil in a clean container.

5 Unscrew oil drain plug (3p) on level controller.

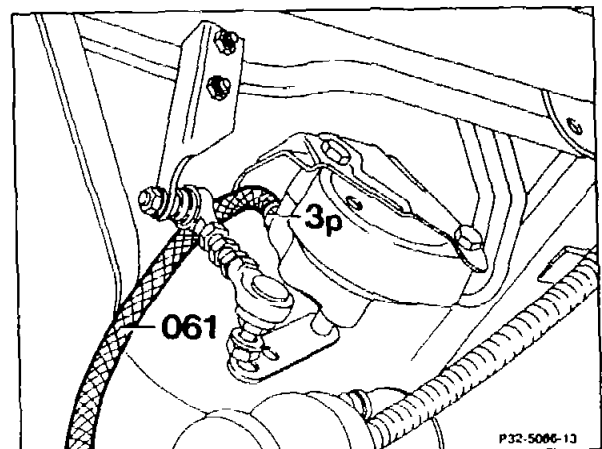

6 Connect pressure tester (038) with test hose (038g) to level controller (3).

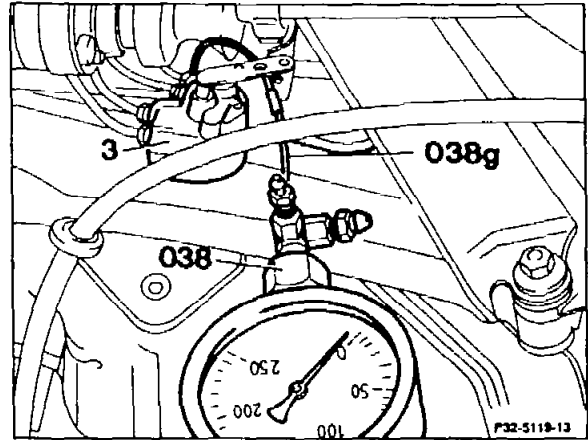

7 Start engine and run at idle.

8 Move lever of level controller to "filling" position, while watching the needle of the pressure gauge.

Nominal value: min. 133 bar.

Note

It is sufficient to achieve the minimum values for evaluating the pressure oil pump and the pressure-relief valve in the level controller (refer to table of test data).

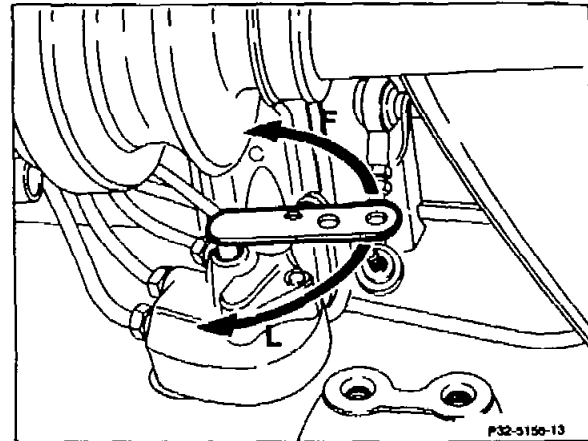

F Filling position
L Emptying position

On account of the high pressures generated, and for the protection of the pressure oil pump as well as of the spring struts and their rebound stops, the test should be of short duration only!

The pressure-relief valve in the level controller is designed for the maximum permissible rear axle load.

If the vehicle is overloaded, the opening of the pressure-relief valve may be indicated by hissing and knocking noises whilst driving.

Note

If the nominal pressure is not attained in vehicles with ASD, perform the ASD pressure test on the hydraulic system (Repair Instructions for rear axle, no.

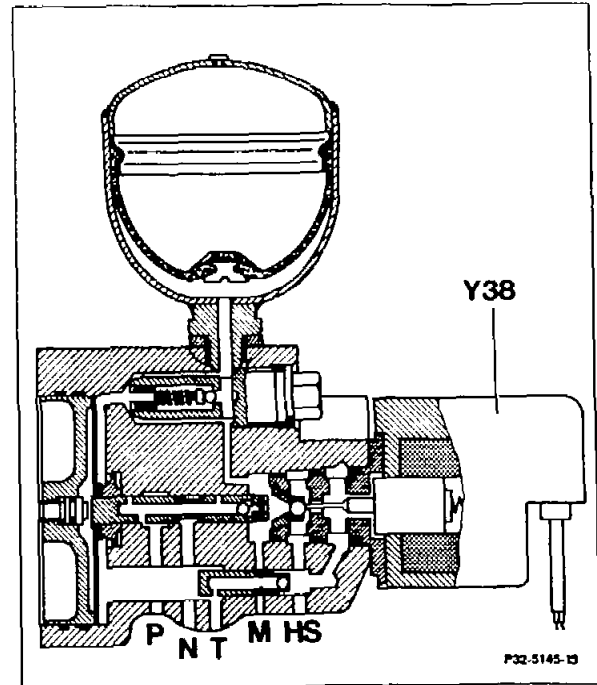

Version up to 5/92

Y38 ASD solenoid valve
P/N/T/HS Line connections
M Test connection

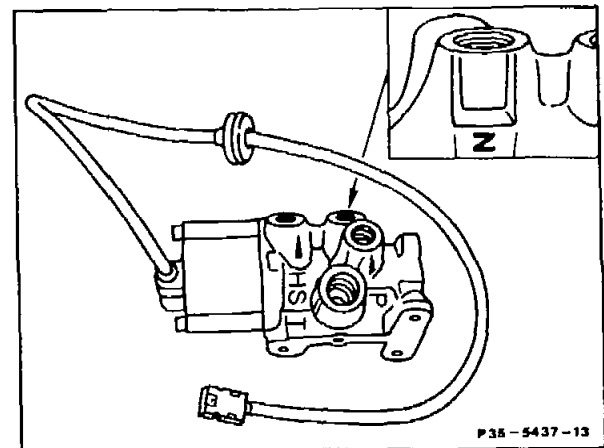

Version as of 6/92

P/N/T/HS Line connections

9 Switch off engine.

10 To check the **basic pressure** following the tests performed in accordance with step 8, set the level controller lever to "emptying".

11 Read off basic pressure on pressure gauge.
Test pressure 30 + 6 bar.

12 After a stabilization period of approx. 5 minutes, read off basic pressure again and leave pressure tester connected for approx. 4 hours. After the stabilization period and after the second reading, the basic pressure should not drop. The same applies for a longer test period, e.g. overnight.

A drop in basic pressure may lead to rumbling noises at the rear axle whilst driving under partial load.

Note

To prevent measurement errors due to possible cooling of the hydraulic oil, the hydraulic oil should not be hot prior to the test. Slight heating, e.g. following a short road test, is not significant.

13 Connect oil drain hose (061) to bleed screw (038n).

14 Slowly open bleed screw (038n) and release pressure. Collect the oil in a clean container.

15 Disconnect pressure tester. Screw oil drain plug into level controller, 14 Nm.

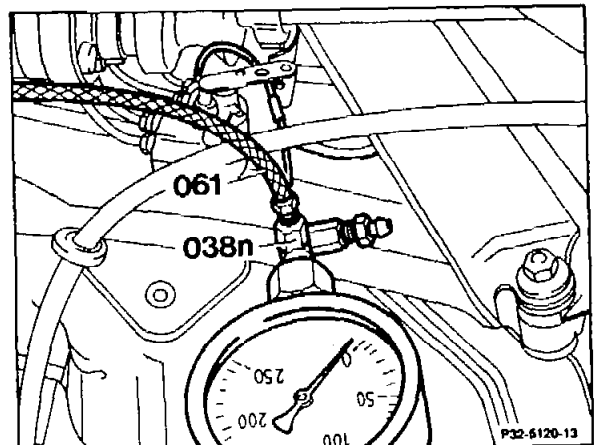

16 Pour collected oil into oil reservoir (2) through the funnel with filter (060).

Note

Only re-use oil if it is clean.

17 Fill pressure oil system (32-0630).

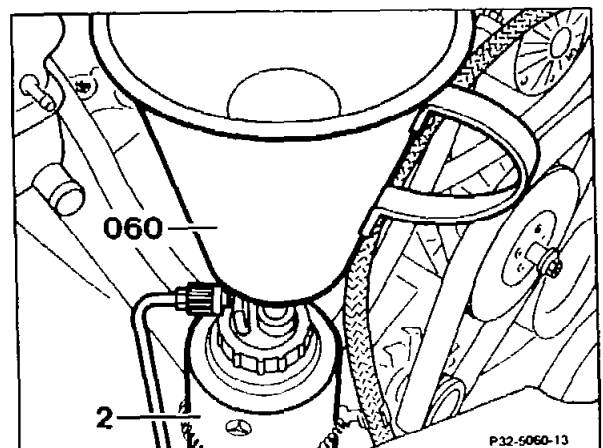

18 Engage connecting rod (7) in lever of level controller and tighten new self-locking hexagon nut (7a), 10 Nm.

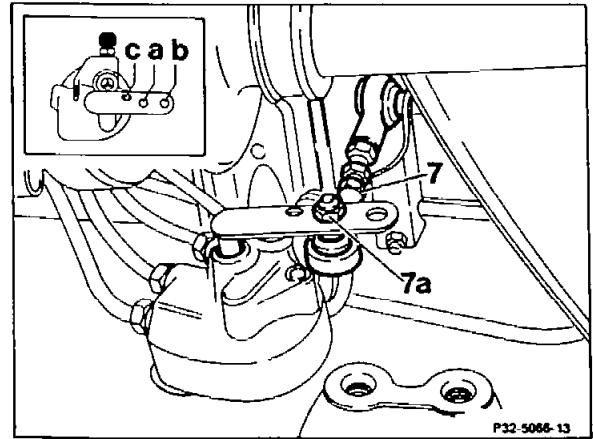

Model 201 in bore "a"

Model 124 in bore "b"

19 Check oil level in oil reservoir (2) with engine stopped and correct if necessary. The oil level in the ready-to-drive condition should be between the "max" and "min" markings.

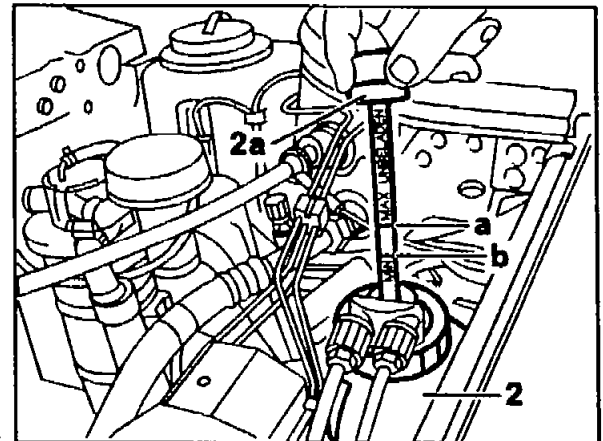

- 2 Oil reservoir
- 2a Cap
- a Maximum mark
- b Minimum mark