

## 07.3-1604 Testing restrictor in fuel distributor for clear passage

Preceding work:  
Testing fuel pressures and internal leaktightness (07.3-1603).

Operation no. of operation texts and work units or standard texts  
and flat rates:  
07-1604.

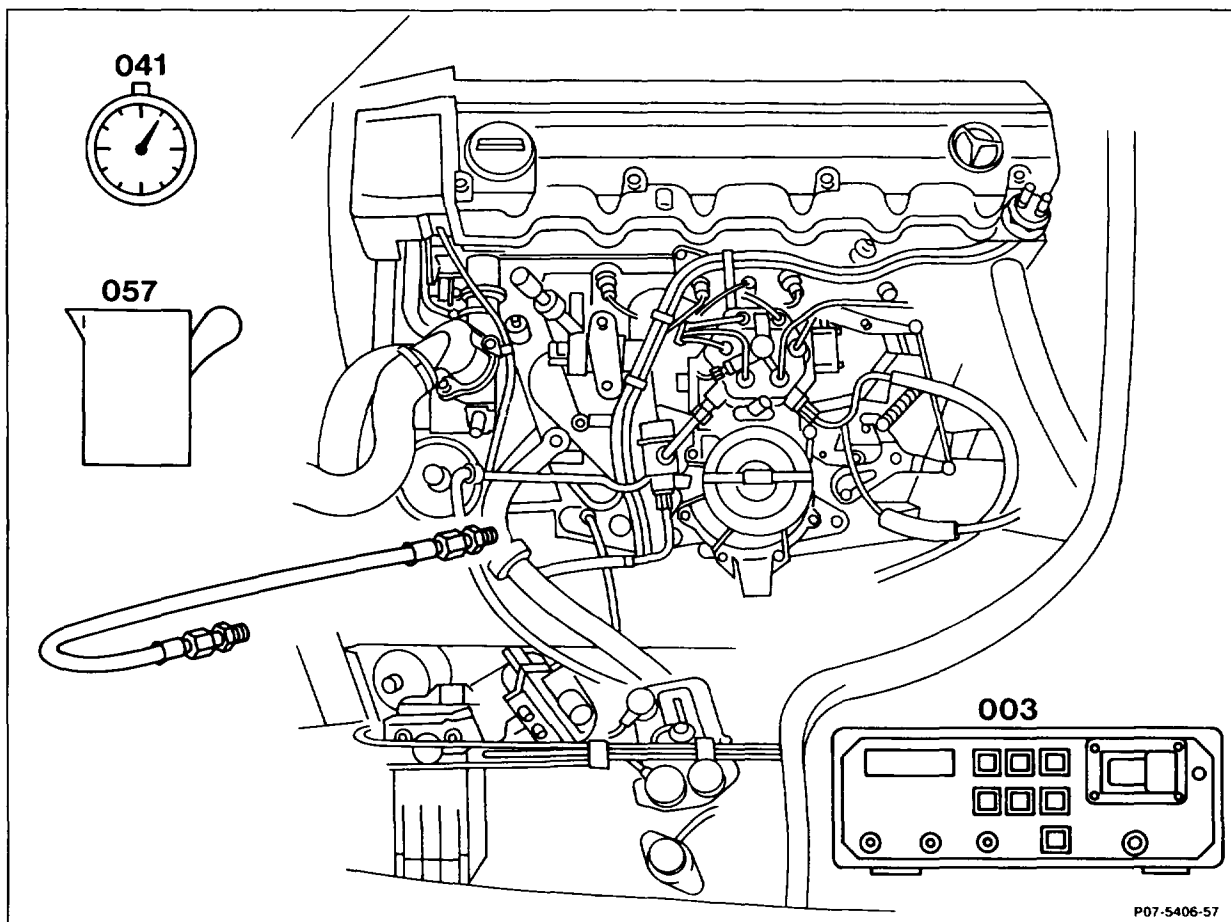

Coupling at actuator .....	unplug. If lambda control fitted, switch on ignition. Separate coupling of oxygen sensor in interior of vehicle.
Fuel line .....	unscrew at fuel distributor and seal with M10×1 screw plug.
Pressure hose .....	connect at fuel distributor and hold in measuring glass or beaker (057). Special tool 102 589 00 21 05.

Fuel pump relay .....	remove and bridge contacts 7 and 8, on model 129 engine systems control unit MAS between contacts 1 and 2 for (USA) (J) as of model year 1990 on KE control unit (N3) between contacts 11 and 20 (fuel pump runs). Special tool 201 589 00 99 00.
Contact bridge .....	remove after 1 minute. Special tool 201 589 00 99 00.
Restrictor .....	check for clear passage. Specification: 130–150 cm <sup>3</sup> /min at minimum voltage of 11.5 V at fuel pump. If specification is not achieved, replace fuel distributor.

### Special tools

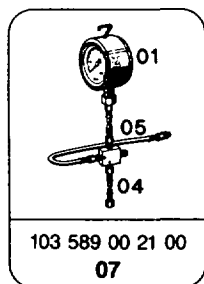

### Commercially available tools and testers (see Workshop Equipment Manual)

Designation	e.g. Make, order no.
Multimeter	Sun, DMM-5
Measuring glass or beaker	
Stop watch	

### Testing

- 1 Unplug coupling at actuator.  
If lambda control fitted, switch on ignition.  
Separate coupling of oxygen sensor in interior of vehicle.

2 Screw fuel connection line (arrow) between fuel distributor and diaphragm pressure regulator onto fuel distributor. Seal unscrewed connection line with M10×1 screw plug so that no fuel flows out.

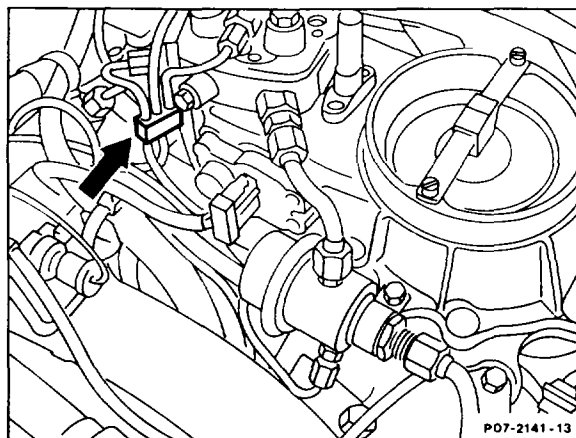

3 Connect fuel pressure hose to fuel distributor and hold in measuring glass or beaker.

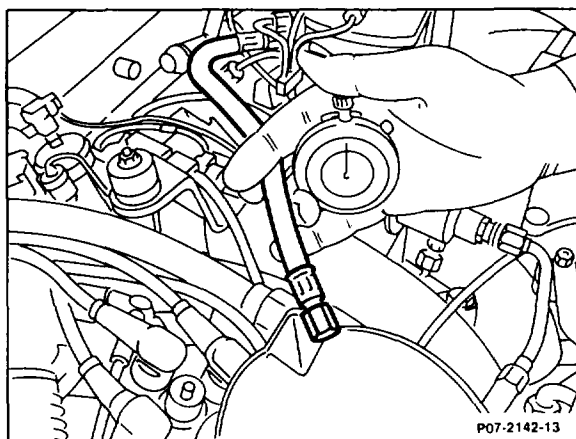

4 Remove fuel pump relays (N16/1 to N16/4).

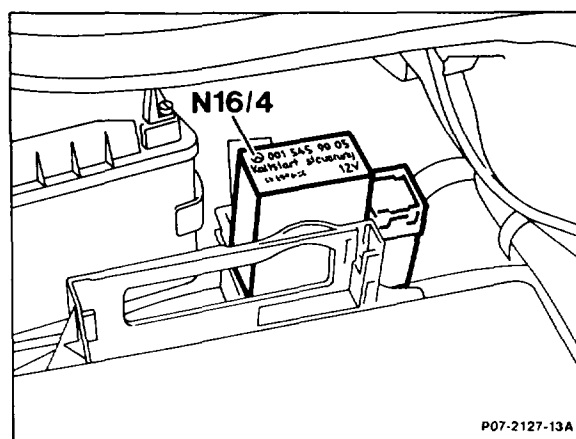

Shown on models 124, 201

5 Bridge contacts 7 and 8, on model 129 engine systems control unit MAS between contacts 1 and 2, for (USA) (J) as of model year 1990 on KE control unit (N3) between contacts 11 and 20. This energizes the fuel pump.

Remove contact bridge after 1 minute.

If the specification of 130–150 cm<sup>3</sup>/minute at a minimum voltage of 11.5 volts at the fuel pump is not achieved, replace fuel distributor.

