

05-2910 Machining valve seat rings

Preceding work:
Valve guides checked (05-2845)

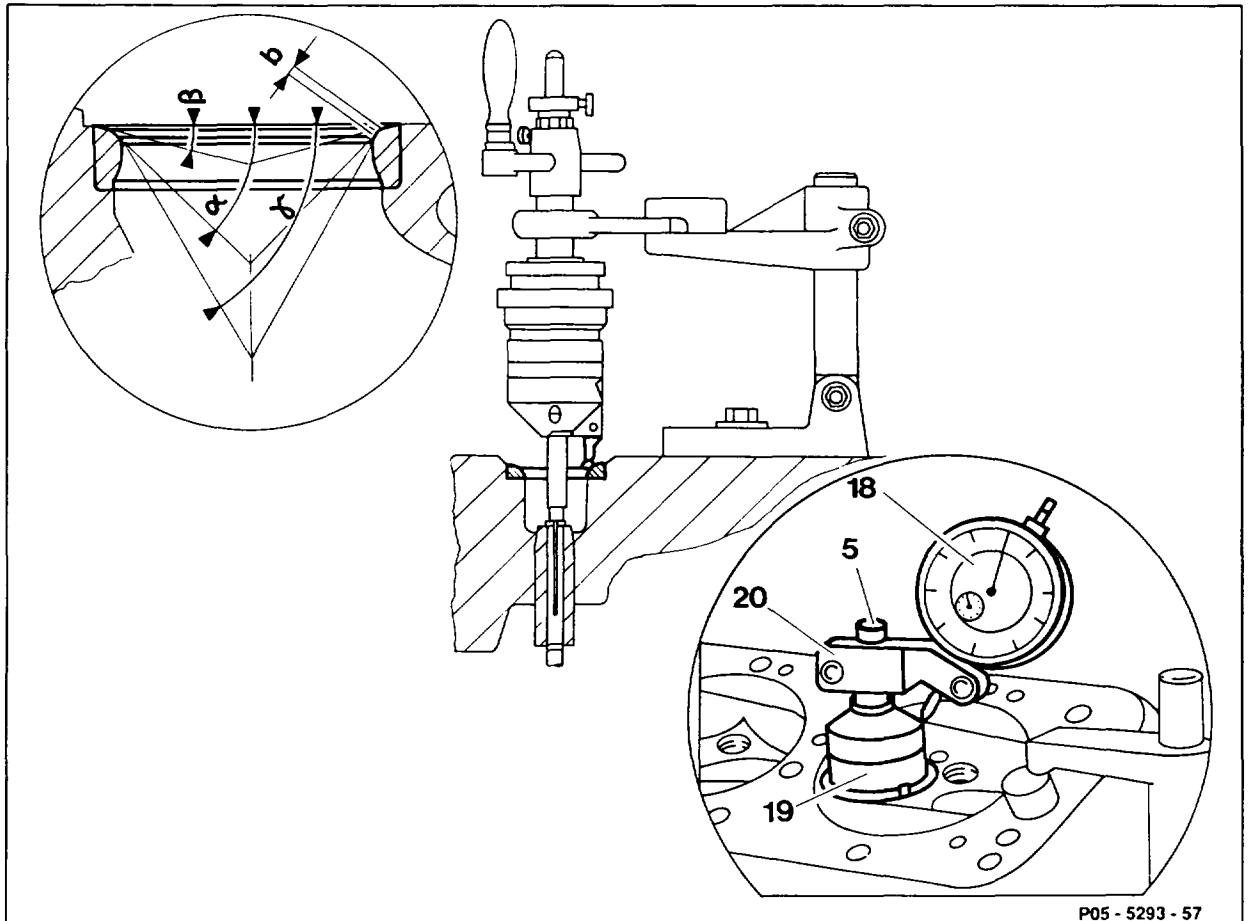

Valve seats	machine.
Operating instructions of tool manufacturer	note.
Dimensions according to table	observe.
Leaktightness with valve installed	check.
Valve seat width (b)	measure.
If necessary correct valve seat width (b) with correction tool 13 (Make Hunger)	(angles β and γ).
Valves	insert and measure distance (A) and (S).
Basic position of hydraulic valve clearance compensating elements	check (05-2130).

Data	Inlet	Exhaust
Valve seat width (b)	1.8 – 2.5 mm	1.5 – 2.5 mm
Valve seat angle (α)		45°
Top correction angle (β)		15°
Bottom correction angle (γ)		60°
Permissible deviation in concentricity of valve seat		0.05 mm

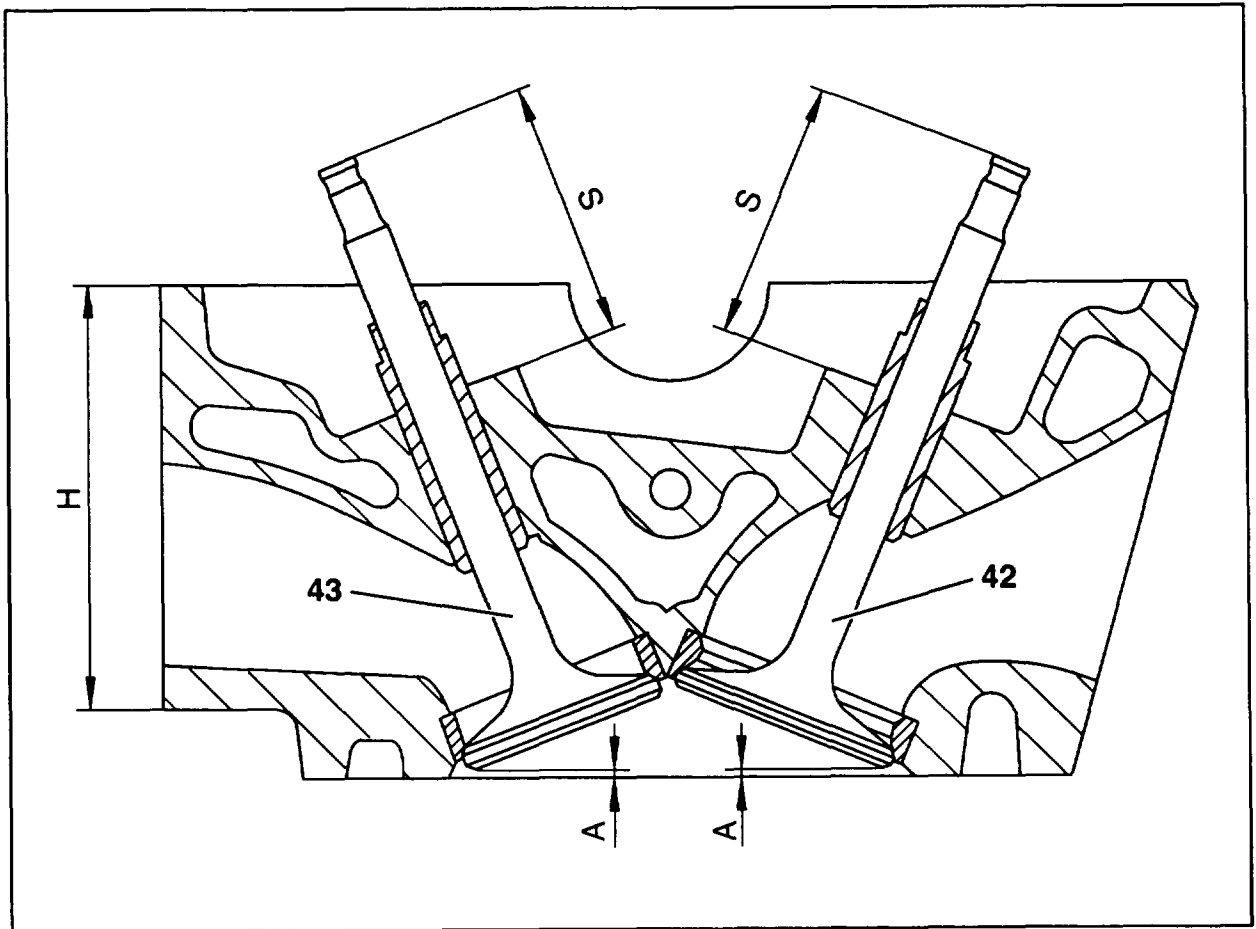

P05-5510-57

Valve clearance relative to cylinder head contact surface and from end of valve stem to contact surface of cylinder head in mm

Engines		103.94	103.98
Minimum distance "A" with new valve seat rings and new valves	Inlet (42)	2.4	1.3
	Exhaust (43)	2.8	1.4
Maximum distance "A" with machined valve seat rings and machined valves	Inlet (42)	3.1	2.0
	Exhaust (43)	3.5	2.1
Distance "S" from end of valve stem to contact surface of cylinder head ¹⁾	Inlet (42)	45.7 – 46.5	45.7 – 46.5
	Exhaust (43)	45.7 – 46.5	45.7 – 46.5

¹⁾ On engine 103.983 AMG the valve contact surfaces on the cylinder head at the inlet and exhaust valves are lowered by 0.5 mm

Commercially available tool

Cylinder head clamping device	eg.	Hunger, D-81309 München 70 Order no. 221.60.000
Valve seat turning tool	eg.	Hunger, D-81309 München 70 Type VDSN 1/45/30, Order no. 236.03.308
Test kit for valve seats	eg.	Hunger, D-81309 München 70 Order no. 216.93.300
60° correction tool no. 13 for bottom correction angle (γ)	eg.	Hunger, D-81309 München 70 Order no. 216.64.622