

01-4070 Servicing spark plug threads in cylinder head

Operation no. of operation texts and work units or standard texts and flat rates

Special tools

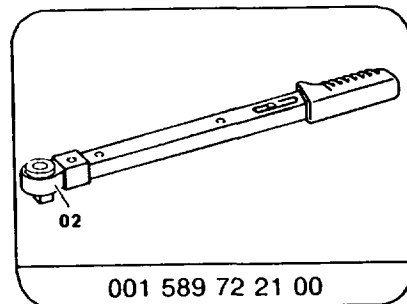
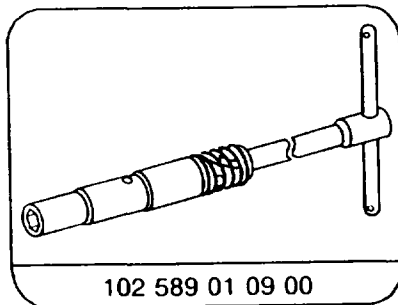
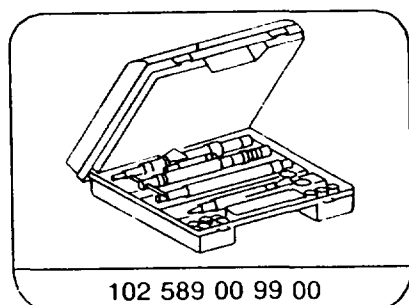

Note

M14 × 1.25 × 14.4 mm HELI-COIL threaded inserts (block length 9.1 mm) can be inserted into the cylinder head with the HELI-COIL Repair Kit 102 589 00 99 00.

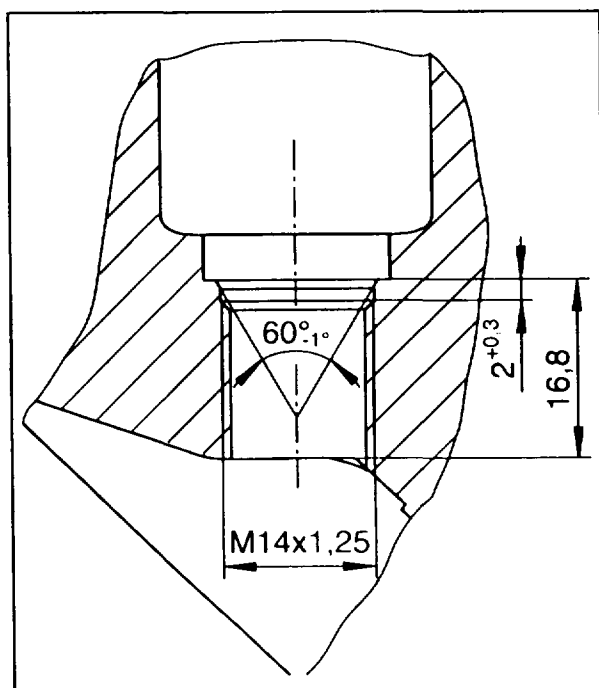

Original thread

P01-6050-15

Servicing

- 1 Remove cylinder head cover, install (01-0500)
- 2 Position piston of the relevant cylinder to 20° - 30° before TDC.

3 Pack grooves (arrows) of combination thread tap (9) of thread tapping unit with grease and screw combination thread tap into the damaged thread. When doing this, push the guide bush (11) into the spark plug recess. Screw in combination thread tap sufficiently until the guide tube (12) touches and is resting against the stop ring (10).



With the cylinder head fitted, remove combination thread tap after approximately each 5 rotations, clean grooves of chips and grease and re-pack with grease.

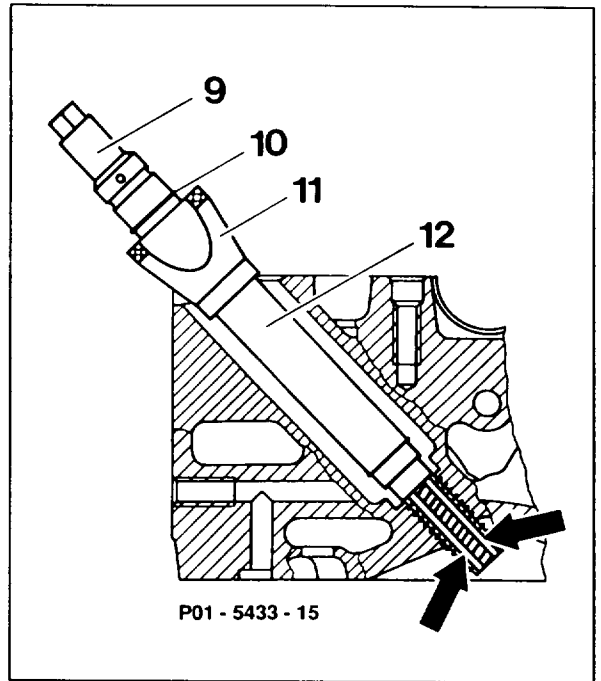

4 Check length of HELI-COIL thread insert (8). Use only the HELI-COIL insert with 9.1 mm block length.

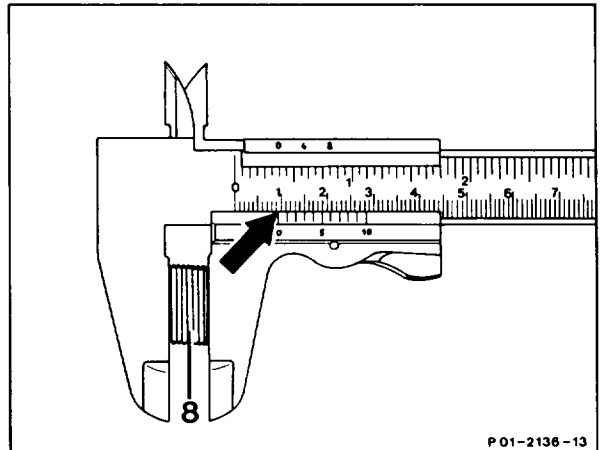

5 Install HELI-COIL thread insert by placing HELI-COIL insert (8) into the fitting tool so that the stub end (arrow) of the insert is facing the pre-tensioning cartridge (16). Turn HELI-COIL insert with the inserting spindle (13) through the pre-tensioning cartridge until the stub end (arrow) is flush with the face end of the pre-tensioning cartridge.

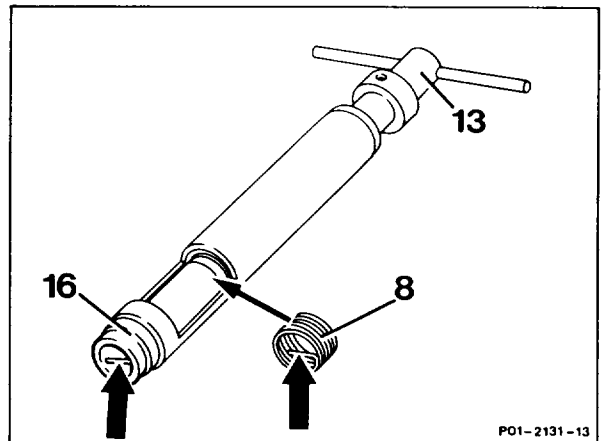

6 Place insertion tool (2) onto the tapped hole, hold casing sleeve (15) tight and turn insertion spindle until the stop ring (14) is touching the casing sleeve.

Note

When inserting the HELI-COIL thread insert, turn back casing sleeve (15) slightly if it jams.

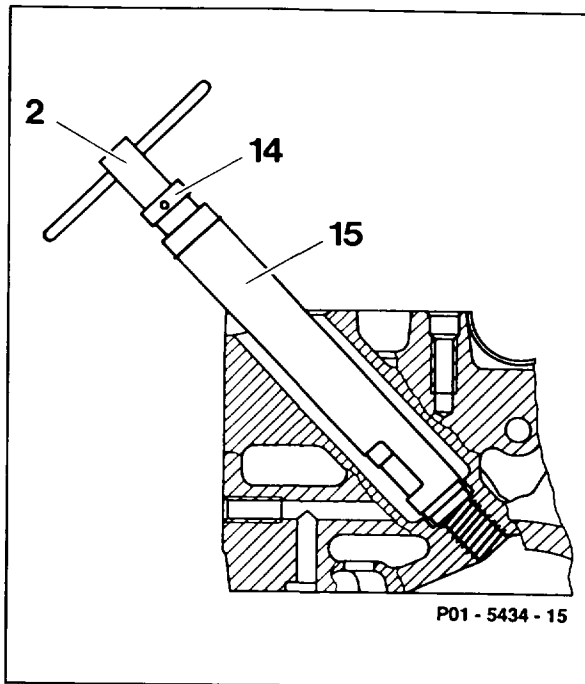

7 Shear off follower stud (arrow) of HELI-COIL threaded insert.

To do this, place sleeve (18) of stud shearing unit over follower stud, insert opened pliers (17) into the sleeve and close pliers. The serrated lock (S) must engage when this is done.

Turn sleeve (18) to the left as far as the stop and hold tight.

Move pliers slightly up and down and brake off follower stud.



If the follower stud inadvertently drops onto the piston crown, it is essential to remove it with a magnet.

8 Crank engine with starter (01-0110) to remove any chips which may have dropped onto the piston crown.

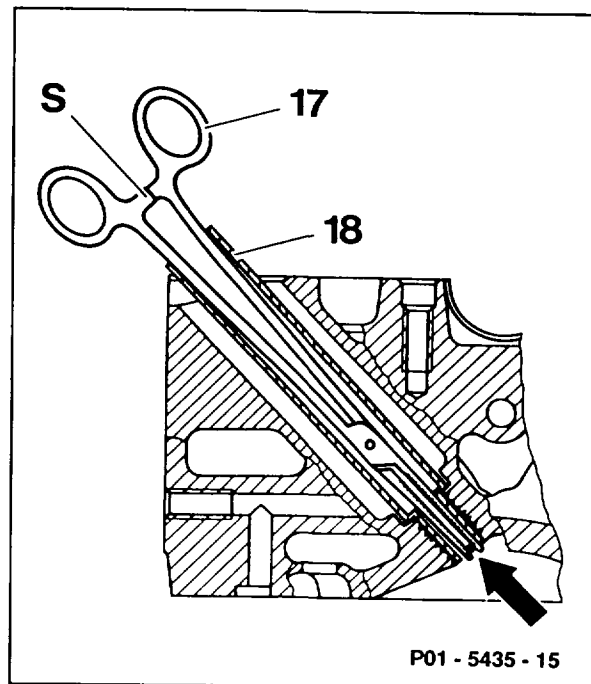

9 Caulk HELI-COIL threaded insert. To do this, grease the tapered thread of the caulking tool (6), screw caulking tool into the installed HELI-COIL insert, tighten to 25 Nm and unscrew caulking tool.

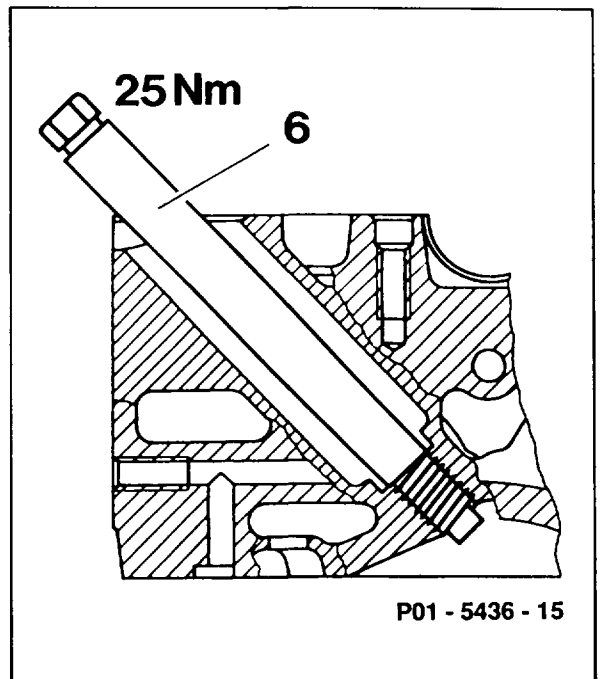

10 Screw in guide drift (4) as far as the shoulder (arrow).

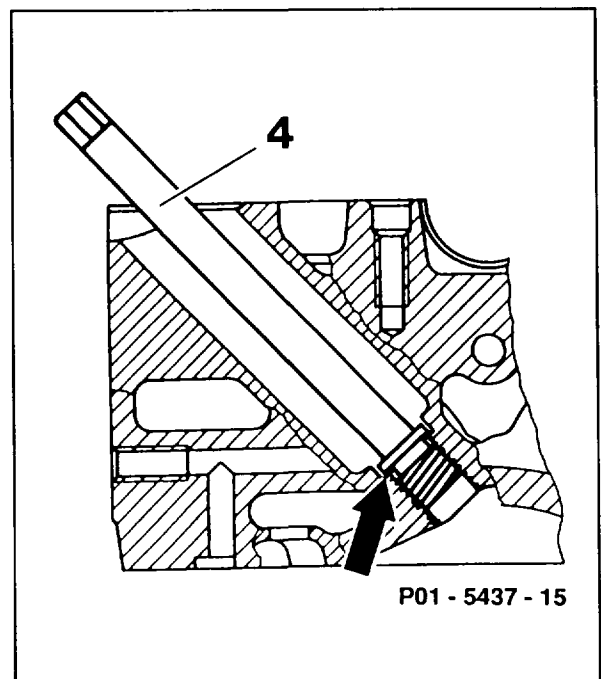

11 Push milling cutter (5) over guide drift (4) and mill seat for copper sealing ring. The required milling depth is reached once the milling cutter is resting on the shoulder (arrow) and no further cutting resistance is felt.



Always blow out milling chips again.

12 First of all thoroughly blow out spark plug recess before removing guide drift (4).

13 Crank engine with starter (01-0110) to remove any chips which may have dropped onto the piston crown.

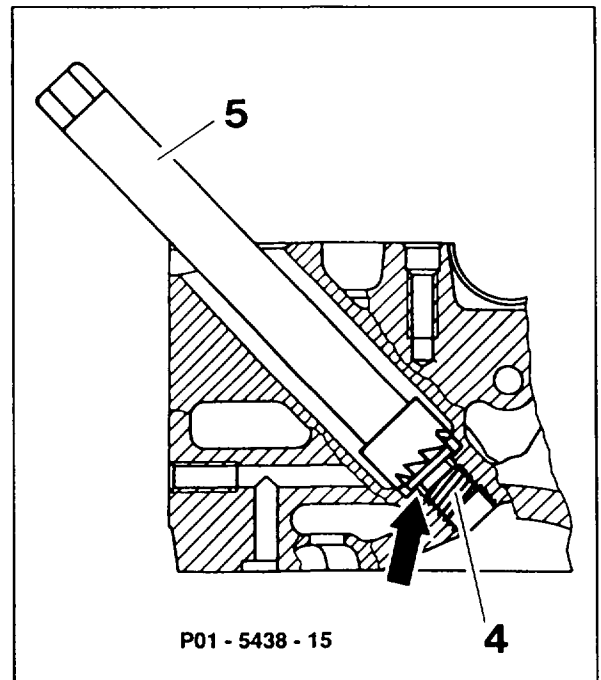

14 Insert copper seal (7) from HELI-COIL Repair Kit into the seat.

15 Screw in spark plug (20) and tighten to 30 Nm so that the tapered seat (arrow) is pressed into the copper ring (7).

16 Slacken spark plug (20) and tighten to 20 Nm.

